

**URGENT**

**MWO effective date is 1 February 1996 and completion date is 31 January 1998.**

**MWO 9-2320-272-20-7**

**BRAKE PROPORTIONING VALVE KIT  
MODIFICATION WORK ORDER**

**MODIFICATION OF 5-TON  
M939, M939A1, AND M939A2 SERIES TRUCKS**

<b>NOMENCLATURE</b>	<b>NSN</b>	<b>EIC</b>	<b>NOMENCLATURE</b>	<b>NSN</b>	<b>EIC</b>
Truck, Cargo, Dropside	2320-01-050-2084	BRY	Truck, Dump	2320-01-230-0305	ZAE
Truck, Cargo, Dropside	2320-01-206-4087	BSS	Truck, Dump	2320-01-047-8755	BTG
Truck, Cargo, Dropside	2320-01-230-0307	ZAA	Truck, Dump	2320-01-206-4080	BSZ
Truck, Cargo, Dropside	2320-01-047-8769	BRT	Truck, Dump	2320-01-230-0306	ZAF
Truck, Cargo, Dropside	2320-01-206-4088	BST	Truck, Tractor	2320-01-047-8753	BTE
Truck, Cargo, Dropside	2320-01-230-0308	ZAB	Truck, Tractor	2320-01-206-4077	BS2
Truck, Cargo, XLWB	2320-01-047-8771	BRV	Truck, Tractor	2320-01-230-0302	ZAG
Truck, Cargo, XLWB	2320-01-206-4089	BSW	Truck, Tractor	2320-01-047-8752	BTG
Truck, Cargo, XLWB	2320-01-230-0309	ZAC	Truck, Tractor	2320-01-205-2684	BS3
Truck, Cargo, XLWB	2320-01-247-8770	BRU	Truck, Tractor	2320-01-230-0303	ZAH
Truck, Cargo, XLWB	2320-01-206-4090	BSX	Truck, Van, Expansibile	2320-01-047-8750	BTB
Truck, Cargo, XLWB	2320-01-230-0310	ZAD	Truck, Van, Expansibile	2320-01-205-2682	BS4
Truck, Dump	2320-01-047-8756	BTH	Truck, Van, Expansibile	2320-01-230-0300	ZAJ
Truck, Dump	2320-01-206-4079	BSY	Truck, Van, Expansibile		
Chassis	2320-01-205-2666		Chassis	2320-01-047-8745	
Chassis	2320-01-230-0287		Chassis	2320-01-230-0288	
Chassis	2320-01-205-2667		Chassis	2320-01-050-4894	

**Headquarters, Department of the Army, Washington, D.C.  
1 February 1996**

**REPORTING ERRORS AND RECOMMENDING IMPROVEMENTS**

You can help improve this MWO. If you find any mistakes or if you know of a way to improve these procedures, please let us know. Write a letter or complete and mail a DA Form 2028, Recommended Changes to Publications and Blank Forms, to: U.S. Army Tank-automotive and Armaments Command, ATTN: AMSTA-IM-MMAA, Warren, MI 48397-5000. A reply will be furnished to you.

DISTRIBUTION STATEMENT A. Approved for public release; distribution is unlimited.

**1. PURPOSE.**

The purpose of this modification is to provide a Brake Proportioning Valve Kit to improve overall braking.

**2. PRIORITY.**

This modification is classified as URGENT.

**3. END ITEM TO BE MODIFIED.**

a. 5-ton, 6x6, M939, M939A1, and M939A2 series trucks.

<b>NOMENCLATURE</b>	<b>NSN</b>	<b>EIC</b>	<b>PART NO.</b>	<b>CAGEC</b>	<b>MODEL NO.</b>
Truck, Cargo, Dropside	2320-01-050-2084	BRY	8736986-2	19207	M923
Truck, Cargo, Dropside	2320-01-206-4087	BSS	8750151	19207	M923A1
Truck, Cargo, Dropside	2320-01-230-0307	ZAA	8750177	19207	M923A2
Truck, Cargo, Dropside	2320-01-047-8769	BRT	8736986-1	19207	M925
Truck, Cargo, Dropside	2320-01-206-4088	BST	8750152	19207	M925A1
Truck, Cargo, Dropside	2320-01-230-0308	ZAB	8750179	19207	M925A2
Truck, Cargo, XLWB	2320-01-047-8771	BRV	8736987-2	19207	M927
Truck, Cargo, XLWB	2320-01-206-4089	BSW	8750155	19207	M927A1
Truck, Cargo, XLWB	2320-01-230-0309	ZAC	8750181	19207	M927A2
Truck, Cargo, XLWB	2320-01-047-8770	BRU	8736987-1	19207	M928
Truck, Cargo, XLWB	2320-01-206-4090	BSX	8750156	19207	M928A1
Truck, Cargo, XLWB	2320-01-230-0310	ZAD	8750182	19207	M928A2
Truck, Dump	2320-01-047-8756	BTH	8736989-2	19207	M929
Truck, Dump	2320-01-206-4079	BSY	8750157	19207	M929A1
Truck, Dump	2320-01-230-0305	ZAE	8750183	19207	M929A2
Truck, Dump	2320-01-047-8755	BTG	8736989-1	19207	M930
Truck, Dump	2320-01-206-4080	BSZ	8750158	19207	M930A1
Truck, Dump	2320-01-230-0306	ZAF	8750184	19027	M930A2
Truck, Tractor	2320-01-047-8753	BTE	8736990-2	19207	M931
Truck, Tractor	2320-01-206-4077	BS2	8750159	19207	M931A1
Truck, Tractor	2320-01-230-0302	ZAG	8750185	19207	M931A2
Truck, Tractor	2320-01-047-8752	BTD	8736990-1	19207	M932
Truck, Tractor	2320-01-205-2684	BS3	8750160	19207	M932A1
Truck, Tractor	2320-01-230-0303	ZAH	8750186	19207	M932A2
Truck, Van, Expansibile	2320-01-047-8750	BTB	8736992	19207	M934
Truck, Van, Expansibile	2320-01-205-2682	BS4	8750161	19207	M934A1
Truck, Van, Expansibile	2320-01-230-0300	ZAJ	8750187	19207	M934A2

NOMENCLATURE	NSN	EIC	PART NO.	CAGEC	MODEL NO.
Chassis	2320-01-047-8745		8736983	19207	M942
Chassis	2320-01-205-2666		8750148	19207	M942A1
Chassis	2320-01-230-0287		8750190	19207	M942A2
Chassis	2320-01-205-2667		8750149	19207	M944A1
Chassis	2320-01-230-0288		8750191	19207	M942A2
Chassis	2320-01-050-4894		8736984	19207	M945

b. Vehicles National Stock Number (NSN) will not change as a result of this MWO.

**4. MODULE.**

Not applicable.

**5. PARTS TO BE MODIFIED.**

Not applicable.

**6. APPLICATION.**

a. Time compliance schedule: MWO effective date is 1 February 1996 and completion date is 31 January 1998.

b. The lowest level of maintenance authorized to apply this MWO is unit maintenance.

c. Work force and man-hour requirements for application of this MWO to a single unit, end item, or system are as follows:

REQUIREMENTS	
WORK FORCE/SKILLS	MAN-HOURS
1 Wheeled-Vehicle Mechanic (MOS 63B) or equivalent	1.5 Hours

Total man-hours required for a single application of this MWO is 1.5 hours.

d. There is no other MWO that must be applied prior to application of this MWO.

e. There is no additional information necessary to apply this MWO.

**7. TECHNICAL PUBLICATIONS AFFECTED/CHANGED AS A RESULT OF THIS MWO.**

<u>Technical Publication</u>	<u>Date</u>
TM 9-2320-272-10	24 July 1984, w/chg 5, 7 Jun, 1993
TM 9-2320-272-20	25 October 1985, w/chg 3, 25 Mar, 1991
TM 9-2320-272-20P	02 September 1988
TM 9-2320-272-34P-1	12 May 1988

**8. MWO KITS, PARTS, AND THEIR DISPOSITION.**

a. The following kit is required to accomplish this modification. The security classification of the kit is unclassified. Shipping data are (estimated):

Weight: 2 lbs.; measurements: 15-in. x 6-in. x 10-in.; Volume 0.09 cu. ft.

<b>NOMENCLATURE</b>	<b>NSN</b>	<b>CAGEC</b>	<b>PART NO.</b>
FRONT BRAKE VALVE KIT	2530-01420-4221	19207	57K3237

b. The Brake Proportioning Valve Kit component parts are listed below. This listing is used to inventory the kit for completeness.

<b>NOMENCLATURE</b>	<b>NSN</b>	<b>CAGEC</b>	<b>PART NO.</b>	<b>QUANTITY</b>
MWO Plate	9905-00-858-5682	19207	10930014	1
Front Brake Valve	4820-00-857-2737	19207	11602155	1
Plate, Template		19207	12450248	1
Strap, Tiedown	5975-00-899-4606	96906	MS3367-2-0	2
Screw	5305-00-253-5614	96906	MS21318-20	1
Nut	5310-00-241-6658	96906	MS51943-34	2
Screw	5305-00-051-4075	80204	B1821BH031F088N	2
Adapter	4730-00-837-1177	81343	8-6 120102B	2
Elbow	4710-00-289-0051	81343	8-6 120202B	1
Elbow	4710-00-289-0051	81343	8-6 100202BA	1

c. Bulk and expendable material used to apply the Brake Proportioning Valve Kit are listed below.

<b>NOMENCLATURE</b>	<b>NSN</b>	<b>CAGEC</b>	<b>PART NO.</b>	<b>QTY.</b>
Pipe Sealant	8030-01-054-0740	05972	592-31	1

d. Parts Disposition. All parts not used during installation will be returned to stock for disposition in accordance with AR 725-50.

**9. SPECIAL TOOLS; TOOL KITS; JIGS; TEST, MEASUREMENT AND DIAGNOSTIC EQUIPMENT (TMDE); AND FIXTURES REQUIRED.**

a. Hand tools necessary to apply MWO are contained in this tool kit:

NOMENCLATURE	NSN	CAGEC	SUPPLY CATALOGUE
Tool Kit, General Mechanic's	5180-00-177-7033	50980	SC 5180-90-CL-N26

b. Metal drilling equipment necessary to apply MWO is contained in this shop set:

NOMENCLATURE	NSN	CAGEC	SUPPLY CATALOGUE
Shop Equipment, Machine Shop: Field Maintenance, Basic	3470-00-754-0708	19204	SC 3470-95-CL-A02

**10. MODIFICATION PROCEDURES.**

a. Vehicle Preparation.

- (1) Remove battery ground cable. (Refer to TM 9-2320-272-20.)
- (2) Drain air reservoirs. (Refer to TM 9-2320-272-10.)
- (3) Remove front limiting valve. (Refer to TM 9-2320-272-20.)

(4) Using 12450248 template plate, locate, mark, and drill two 0.125-inch diameter pilot holes in support bracket as shown in figure 1.

(5) Enlarge two 0.125-inch diameter pilot holes drilled in step (4) to 0.344-inch diameter holes as shown in figure 1.

b. Front Brake Valve Installation.

**NOTE**

Ensure when applying pipe sealant that first two starter threads are clear of pipe sealant.

(1) Remove nut, insert, and sleeve from 8-6 100202BA elbow. Apply 592-31 pipe sealant to threads on elbow and install into supply port of 11602155 front brake valve as shown in figure 2.

(2) Apply pipe sealant to threads on 8-6 120202B elbow and install into exhaust port of front brake valve as shown in figure 2.

(3) Apply pipe sealant to threads on two 8-6 120102B adapters and install into left and right delivery ports of front brake valve as shown in figure 2.

(4) Secure front brake valve to support bracket with two B1821BH031F088N screws and MS51943-34 nuts as shown in figure 3.

**NOTE**

The color of lines (for steps (6), (7), (8), and (9)) has been added as an aid for installation purposes.

(5) Connect two existing application lines (front service brake) to adapters (left and right delivery ports) as shown in figure 4.

**NOTE**

Elbows on front brake valve may need adjustment for line installations. Vent line may need rerouting around existing lines. If rerouting of vent line takes place, be sure that chaffing doesn't occur.

- (6) Connect existing vent line to elbow (exhaust port) as shown in figure 4.
- (7) Cut control line (to needed length) to fit between double checkvalve and elbow (8-6 100202BA) (supply port) as shown in figure 4.
- (8) Install nut, sleeve, and insert (part of elbow 8-6 100202BA) on control line as shown in figure 4.
- (9) Connect control line to elbow (supply port) as shown in figure 4.

**NOTE**

Two tiedown straps are provided with kit. Use second tiedown strap if needed.

- (10) Secure lines with MS3367-2-0 tiedown strap as shown in figure 4.
- (11) Close air reservoir drainvalves. (Refer to TM 9-2320-272-10.)
- (12) Connect battery ground cable. (Refer to TM 9-2320-272-20.)
- (13) Start engine, build up air pressure, apply pressure to brake pedal, and observe for air leaks from lines on front brake valve.
- (14) Road test vehicle.

**11. CALIBRATION REQUIREMENTS.**

Not applicable to this MWO.

**12. WEIGHT AND BALANCE DATA.**

Weight and balance are not significantly affected by this MWO.

**13. QUALITY ASSURANCE REQUIREMENTS.**

a. General. The following information is supplied to ensure the proper application of this modification and provide clarification in regard to the adequacy of the installer's inspection methods and procedures applicable to quality assurance. The procedures include, but are not limited to, installer responsibilities, government verification, and in-process and workmanship inspections. Inspections shall be in accordance with TM 750-245-4.

b. Installer Responsibilities. The installer is responsible for compliance with quality assurance requirements specified herein. These requirements and the installer's plan of inspection, or quality program, constitute the minimum examinations and tests necessary to assure compliance with established requirements. Requirements contained in this MWO shall be included in the installer's inspection plan or quality program. Specific installer responsibilities for this modification work order are as follows: The installer is responsible for following instructions contained in this MWO, for installation of the Brake Proportioning Valve Kit, and for follow-on tasks IAW MWO 9-2320-272-20-7. Installer is responsible for notifying the Government representative if kit was received incomplete or received in open or damaged packaging material. The installer is responsible for quality workmanship.

c. In-Process Inspection. During normal assembly operations, paragraph 10, Modification Procedures, will be used to check the installer's work. If front brake valve fails to operate properly after kit installation, servicing will be conducted in accordance with TM 9-2320-272-20. All defects will be corrected by the installer before the vehicle is placed in service. All vehicles modified during a production shift will be checked to ensure product quality.

d. Workmanship Inspection. Inspect components removed, installed or replaced during the modification for security of mounting. Inspect painted areas of the bumper for missing, chipped, or cracked paint and correct if necessary.

**14. RECORDING AND REPORTING OF THE MODIFICATION.**

a. Records and Report Forms. Refer to DA Pam 738-750, DA Pam 738-751, and TB 9-1100-803-15.

b. Marking Equipment.

(1) After Brake Proportioning Valve Kit is installed, mark "MWO 9-2320-272-20-7" in the MWO applied block, and date in date block on 10930014 MWO instruction plate as shown in figure 5.

(2) Install MWO instruction plate by drilling a 0.104-inch diameter hole (#37 drill) in cab body reinforcement panel and secure with MS21318-20 screw as shown in figure 5.

(3) After screw is installed, flatten or remove protruding excess screw material from inside of cab body reinforcement panel.

**15. MATERIAL CHANGE (MC) NUMBER.**

This MWO is authorized by MC number 1-95-06-4498.

**16. MODIFICATION IDENTIFICATION.**

a. When installed correctly, Brake Proportioning Valve Kit will appear on MWO label as shown in figure 5.

b. After the Brake Proportioning Valve Kit is installed, the front brake valve shall be tested for proper operation. Any faults detected or discrepancies noted will be corrected before the vehicle is returned to normal service.

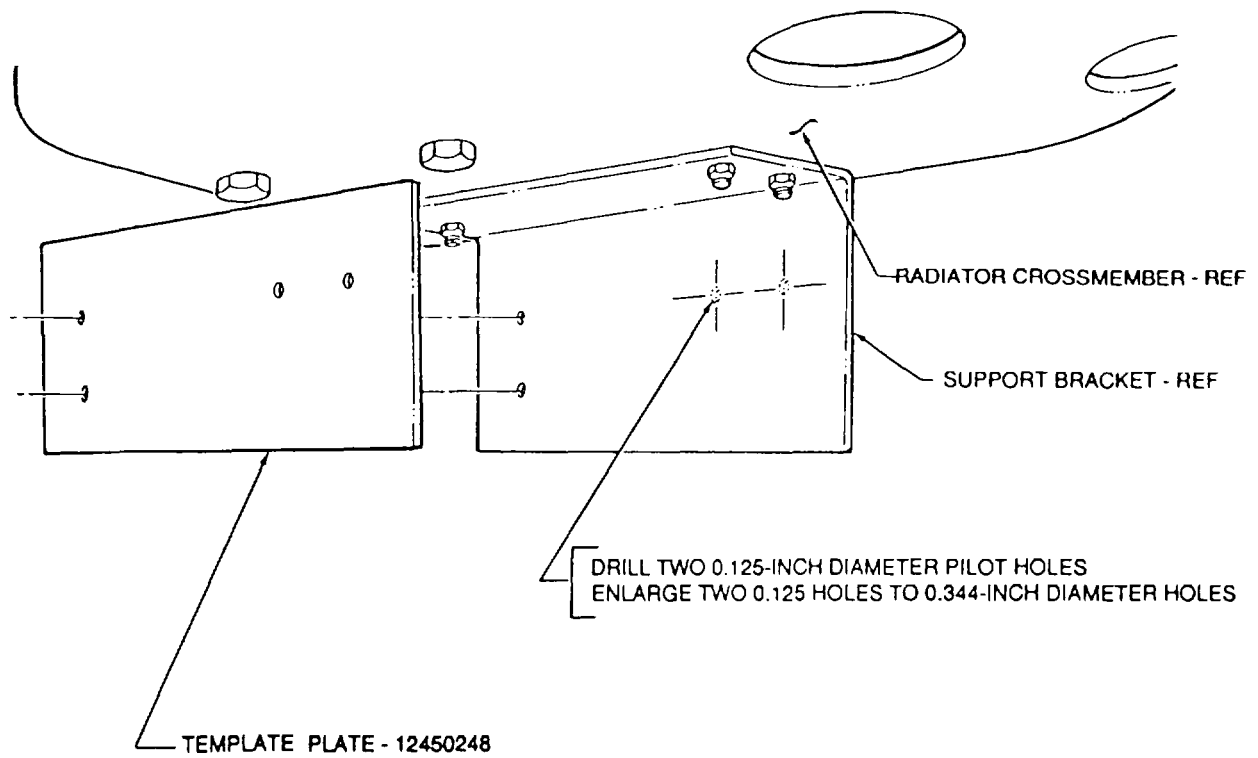
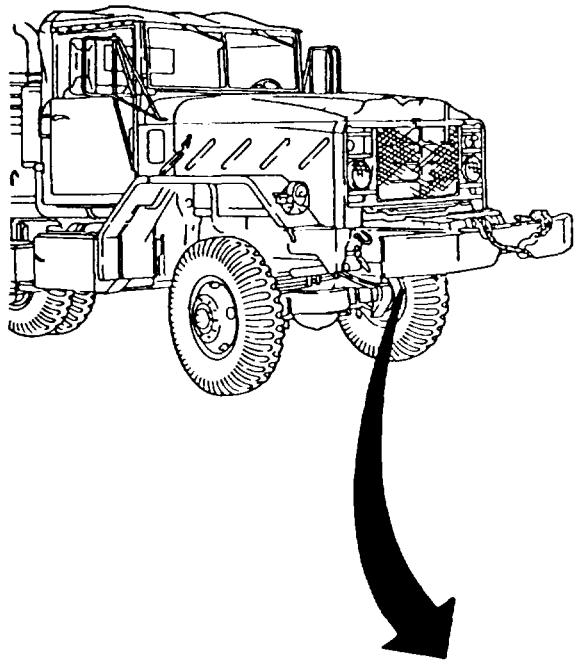

FIGURE 1



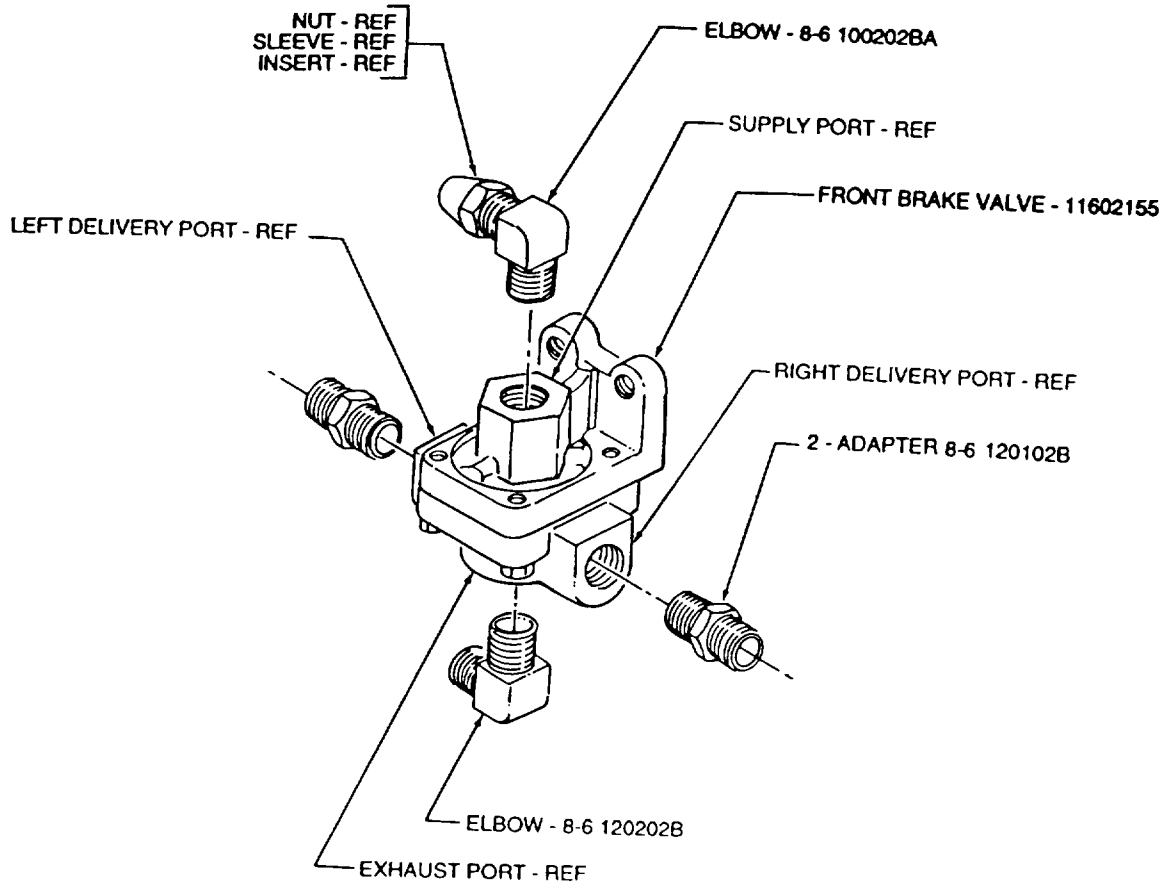

FIGURE 2

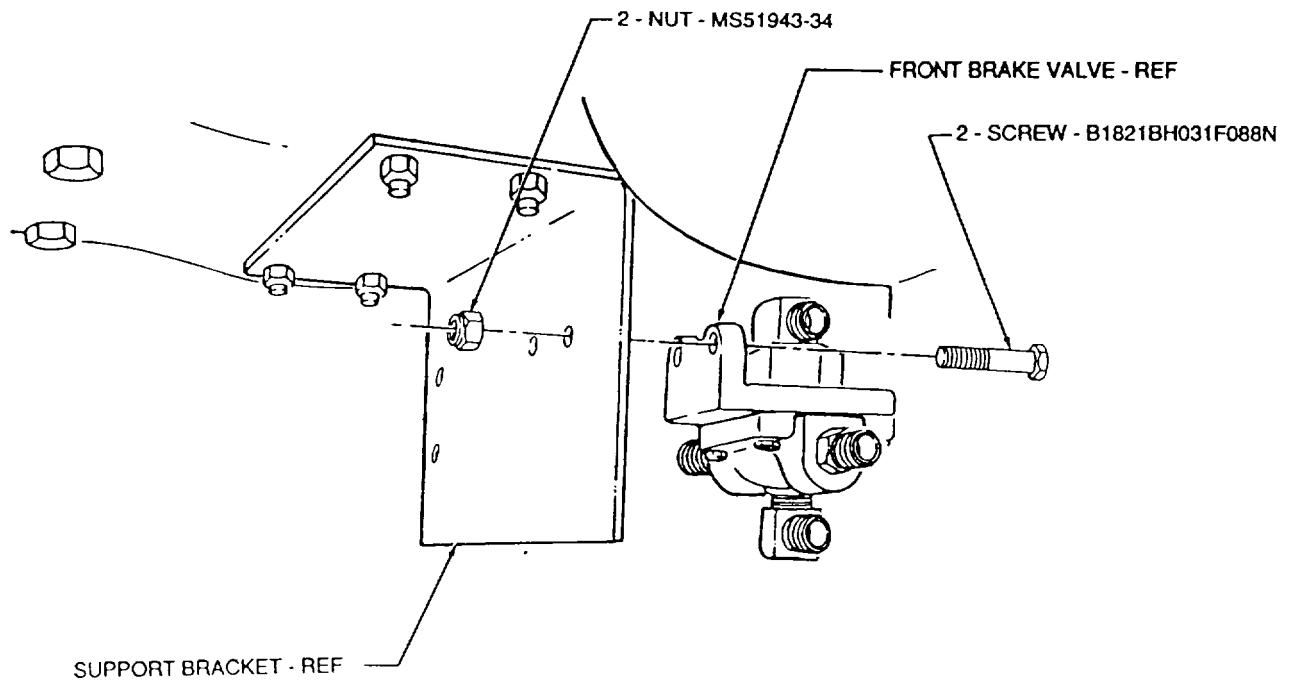

FIGURE 3

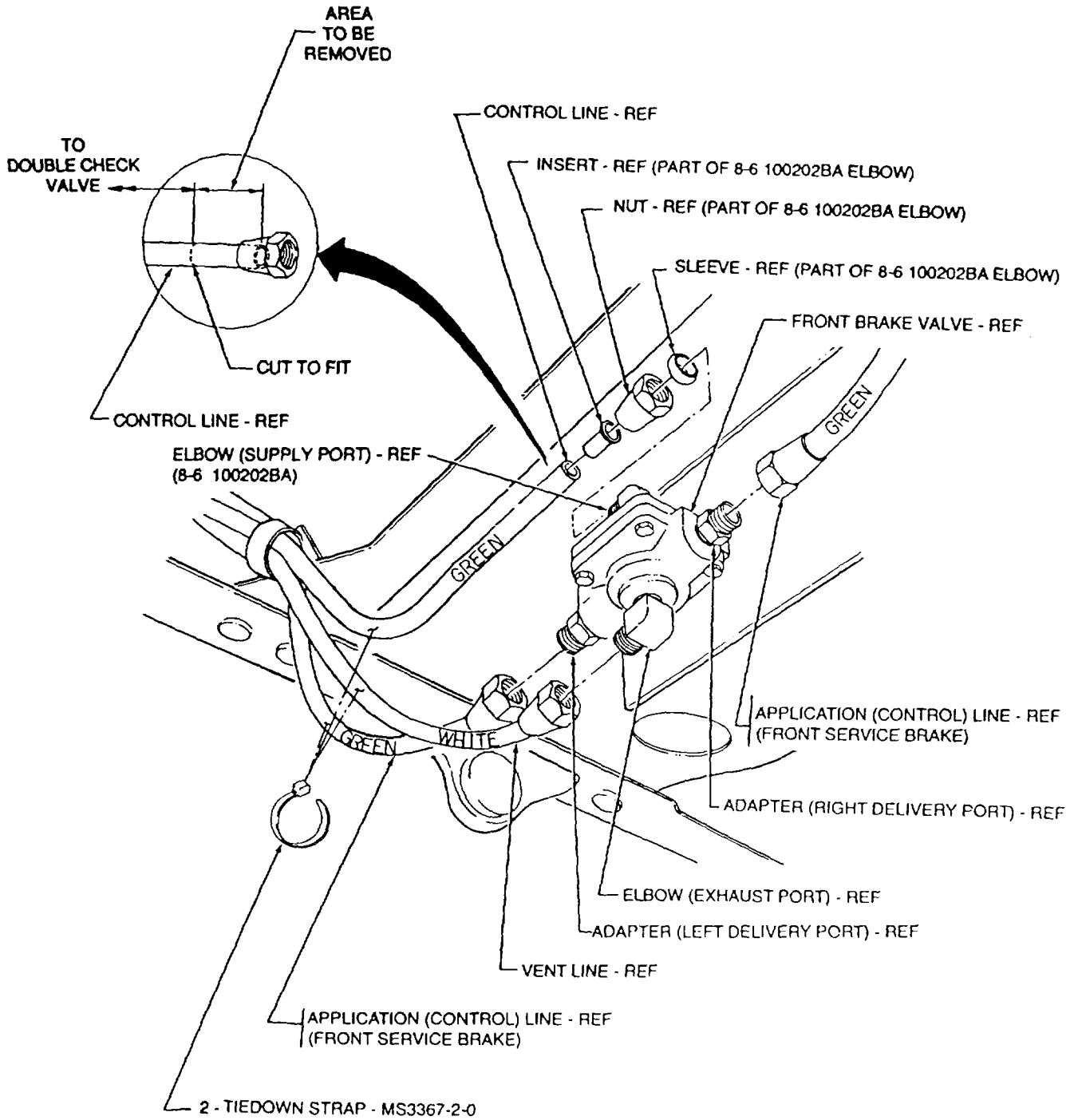

FIGURE 4

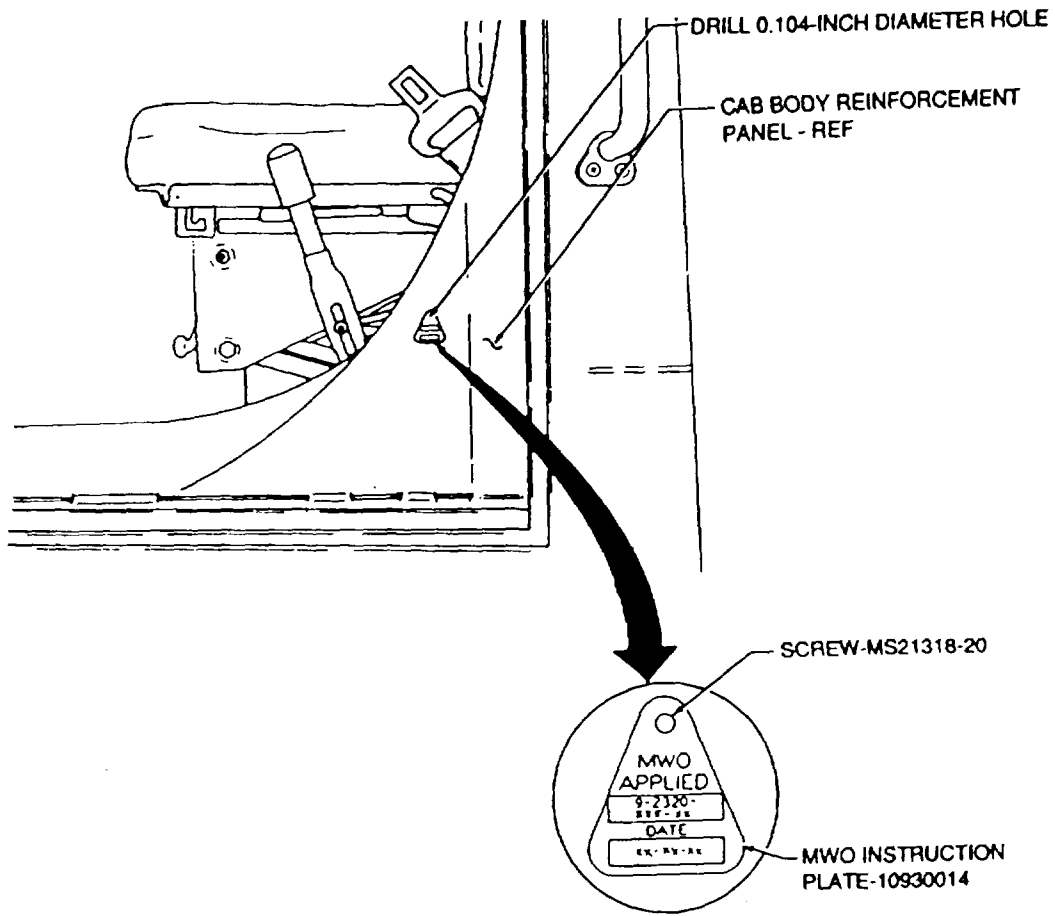
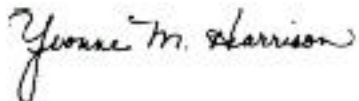

FIGURE 5

By Order of the Secretary of the Army:



*Administrative Assistant to the  
Secretary of the Army*  
01385

**DENNIS J. REIMER**  
*General, United States Army*  
*Chief of Staff*

**DISTRIBUITION:**

To be distributed in accordance with DA Form 12-38E, block 1013, requirements for MWO 9-2320-272-20-7.

★ U.S. GOVERNMENT PRINTING OFFICE: 1996 746-014/20169

RECOMMENDED CHANGES TO EQUIPMENT TECHNICAL PUBLICATIONS



THEN... JOT DOWN THE DOPE ABOUT IT ON THIS FORM, CAREFULLY TEAR IT OUT, FOLD IT AND DROP IT IN THE MAIL!

**SOMETHING WRONG WITH THIS PUBLICATION?**

FROM: (PRINT YOUR UNIT'S COMPLETE ADDRESS)

DATE SENT

PUBLICATION NUMBER

PUBLICATION DATE

PUBLICATION TITLE

BE EXACT... PIN-POINT WHERE IT IS

IN THIS SPACE TELL WHAT IS WRONG AND WHAT SHOULD BE DONE ABOUT IT:

PAGE NO.	PARA-GRAPH	FIGURE NO.	TABLE NO.
----------	------------	------------	-----------

TEAR ALONG PERFORATED LINE

PRINTED NAME, GRADE OR TITLE, AND TELEPHONE NUMBER

SIGN HERE:

DA FORM 2028-2 JUL 79

PREVIOUS EDITIONS ARE OBSOLETE.

P.S.—IF YOUR OUTFIT WANTS TO KNOW ABOUT YOUR RECOMMENDATION MAKE A CARBON COPY OF THIS AND GIVE IT TO YOUR HEADQUARTERS.

